

UNIPHONE MODEL SIGNO REF. 1140/622

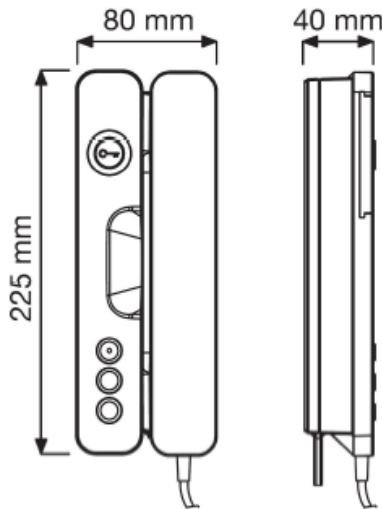

GENERAL INFORMATION

BASIC FUNCTIONS

- Keeping the conversation going.
- Opening the door.

In addition, the uniphone has a built-in service LED indicating the call.

CONNECTION TO THE SYSTEM

The uniphone ref. 1140/622 is connected to a common riser with 2 wires. The uniphone can work within one system with uniphones ref. 1131/62x, ref. 1132/62x, ref. 1134/62x.

Note: the uniphone ref. 1140/622 should work in a 7V system (parameter 1.10 set to 1).

DESCRIPTION OF WIRE CLAMPS

- LU** A line of uniphones.
- OL** Mass of the line of uniphones.
- T1** Call button connection terminal 68R (shorted to ground (OL)).
- T2** Call button connection terminal 180R (shorted to ground (OL)).

PROGRAMMING

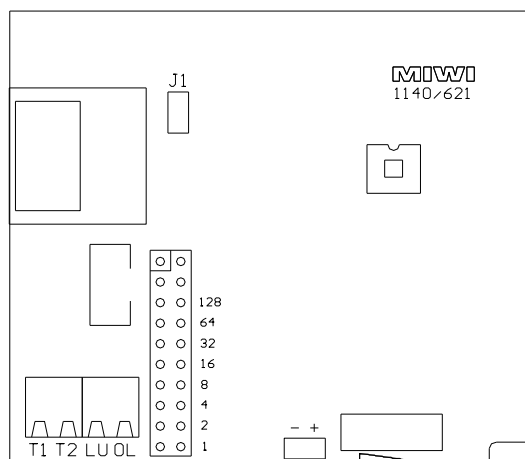

The uniphone is programmed with jumpers. With their help, we set the uniphone number from 1 to 255. The first jumper (from the bottom

of the PCB) is number 1. We use only the first 8 jumpers (counting from the bottom of the PCB), the other two are used to test the uniphone. The uniphone number is set in binary code. Each jumper you put on increments the uniphone number by the number corresponding to the jumper.

Below is a table with example jumper settings. A single power supply of the Matibus SE system or a panel of the BASIC system can support up to 510 users.

In the BASIC system, the logical code of the uniphone is equal to the value set by jumpers in the binary code.

In the Matibus SE system, the logical code of the uniphone is equal to the value set by jumpers in the binary code (for vertical no. 1). For riser no. 2, the logical code of the call is equal to the number set by jumpers plus the number of uniphones set in option 704 (factory 25). Of course, there are factory settings. It is possible to modify the logical codes in any way.

Jumper alignment	Uniphone call code
128 64 32 16 8 4 2 1 	1
128 64 32 16 8 4 2 1 	25
128 64 32 16 8 4 2 1 	12
128 64 32 16 8 4 2 1 	240
128 64 32 16 8 4 2 1 	129

ADJUSTING THE CALL TONE VOLUME

Under the handset hanger there is a 3-position lever for adjusting the volume of the call signal.

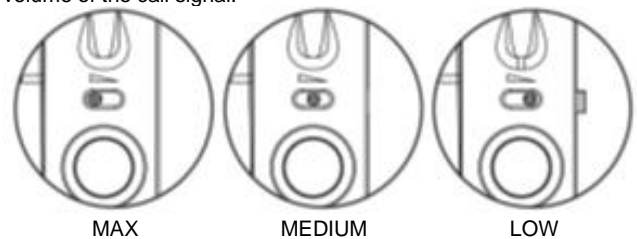

Jumper J1 is the service jumper.

Terminals T2 and T1 (depending on the configuration in the power supply programming menu) can be used to control the OC1, OC2 outputs or to call the porter control panel. Pressing the button in the vertical 1 uniphone will open the OC2 output, while in the vertical 2 uniphone will open the OC1 output. When OC1 and OC2 are connected to the EI input, then it is possible to control the door using the uniphone without the use of additional wiring.

T1 is the terminal of the 68R resistor while T2 is the terminal of the 180R resistor.

Terminal T2 is connected to function button no. 1 at the factory. Terminal T1 is connected to function button No. 2.

Unit weight 0.3 kg

ASSEMBLY

The SIGNO uniphone can be mounted on a wall or placed on a desk using an inclined base.
The device is designed to work indoors. They should be installed in dry places.
The device is not dust resistant.

WALL MOUNTING

It is advisable to install the uniphone at such a height that the highest part of the device is at a height of 1.55 m from the ground.
To mount the uniphone in a hanging version, follow the steps described below.

1. Unfold the uniphone housing by releasing the plastic latches using a screwdriver blade (Fig. 1).

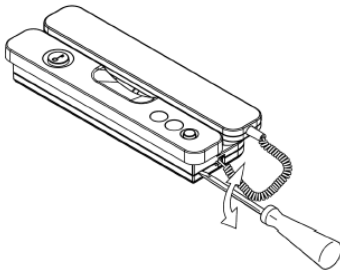

Fig. 1

2. Attach the uniphone to the wall using the 2 wall plugs supplied with the uniphone (Fig. 2).
3. Feed the cables through the hole in the back of the uniphone.
4. Shorten the wires to the required length and strip the ends.

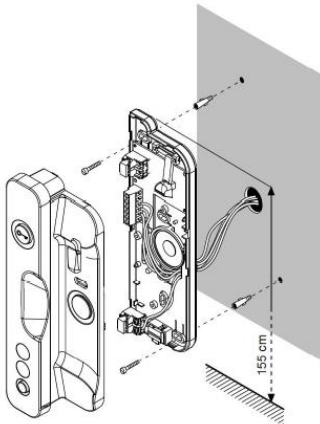

Fig. 2

5. Connect the wire ends to the correct terminals of the uniphone connector.
6. Reconnect the two parts of the housing (Fig. 3).

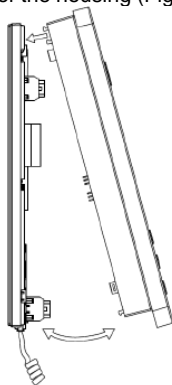
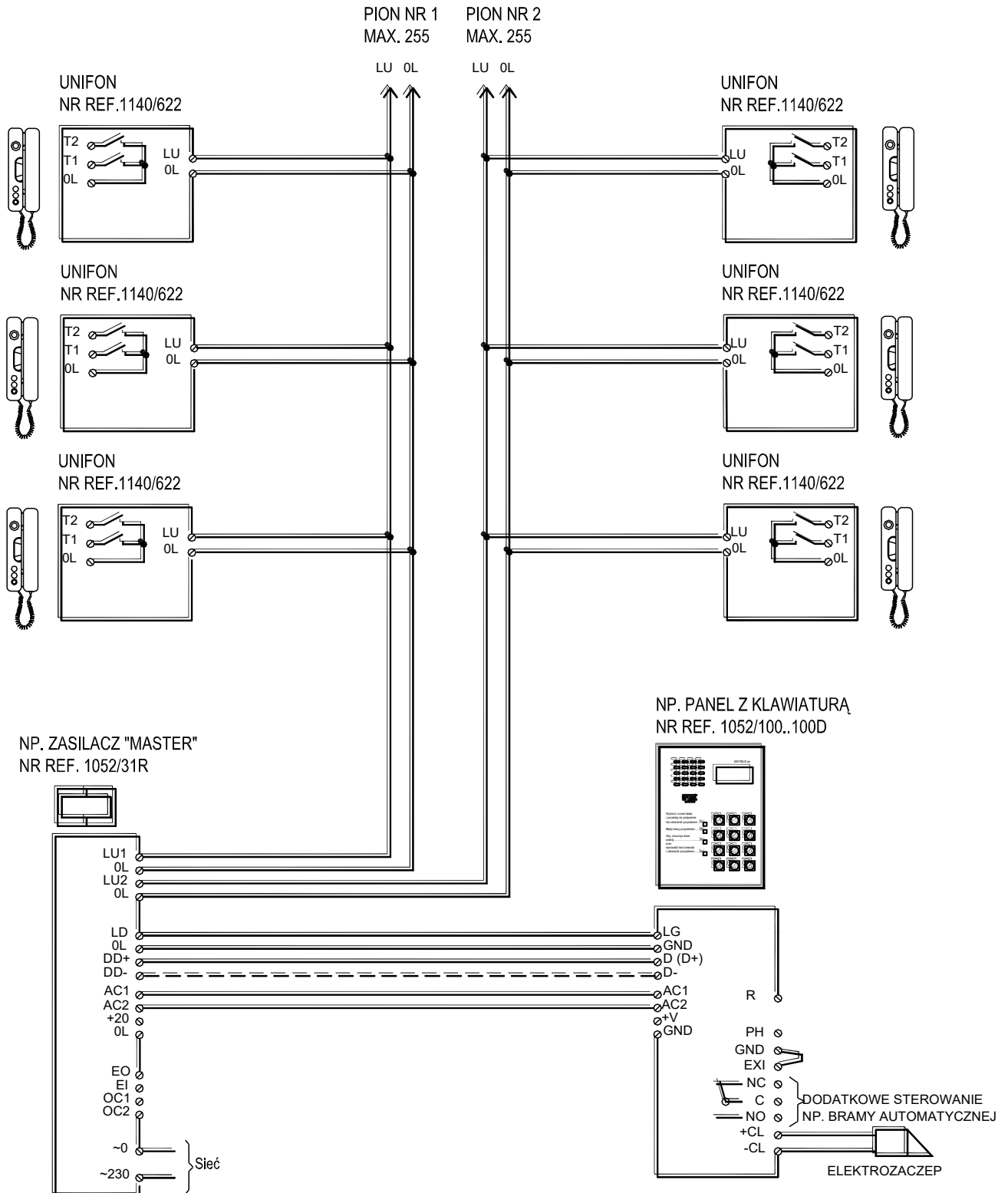

Fig. 3

CONNECTION DIAGRAM IN THE MATIBUS SE SYSTEM



MIWI-URMET Sp. z o. o.
Pojezierska 90A
91-341 Lodz
phone: (0-42) 616-21-00
fax: (0-42) 616-21-13

Email: miwi@miwiurmet.pl
<http://www.miwiurmet.pl>

Of 22.05.2025

Instruction regarding the use of electrical and electronic equipment in the European Union countries.

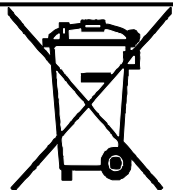

This symbol on the product, on the packaging or in the user manual, means that the device should not be disposed of like normal waste, but should be disposed of at the appropriate collection point/collection point for waste electrical and electronic equipment operating in the recycling system in accordance with the Act of 29 July 2005 on waste electrical and electronic equipment *{D.U. of 2005 No. 180, items 1494 and 1495}*

Following the above guidelines allows you to avoid potential negative consequences for the environment and human health resulting from improper storage and processing of waste electrical and electronic equipment. (WEEE). If possible, please remove the batteries and/or accumulators from the device and hand them over to collection points in accordance with the applicable requirements. Following the above rules related to the recycling of waste equipment and materials allows you to maintain resources and natural resources.
